

OFFER YOUR CUSTOMERS
A UNIQUE WELL-BEING
EXPERIENCE IN THE SHOWER.

**SKINJAY
SOLUTION
BUSINESS**

2018



S
K
I
N
J
A
Y

A NEED FOR
SWITCHING OFF
WELL-BEING,
AND NATURALNESS

“OUR GOAL IS TO ENSURE
EVERYONE’S WELL-BEING,
ANYWHERE AND ANYTIME,
BY TRANSFORMING
THE SHOWER INTO A HAVEN OF
SERENITY DEDICATED
TO HEALTH AND WELL-BEING.”

NICOLAS PASQUIER

Founder of Skinjay





S
K
I
N
J
A
Y

A DYNAMIC DEVELOPMENT

2012

CREATION OF SKINJAY BY NICOLAS PASQUIER

- _ Research and development
- _ Patent filing worldwide

2015

LAUNCH IN FRANCE OF SKINJAY BUSINESS SOLUTIONS

- _ 1st luxury hotel equipped

2016

LAUNCH IN EUROPE OF SKINJAY BUSINESS SOLUTIONS

2017

LAUNCH IN EUROPE FOR THE GENERAL PUBLIC

2018

INTERNATIONAL DEPLOYMENT OF SKINJAY BUSINESS SOLUTIONS



S
K
I
N
J
A
Y

SKINJAY IN NUMBERS



150 RECOMMENDATIONS

from 4-star and 5-star
hotels & luxury hotels
in France and abroad



6 PATENTS FILED

worldwide

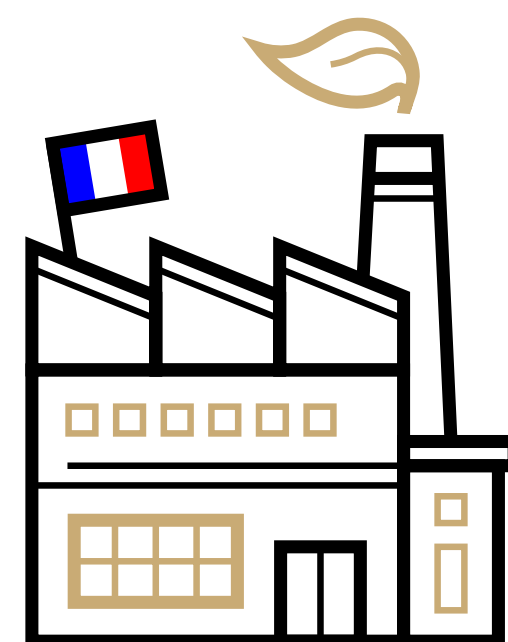

6 PRODUCTION SITES

exclusively
in FRANCE



3 YEARS OF R&D

In-house engineers

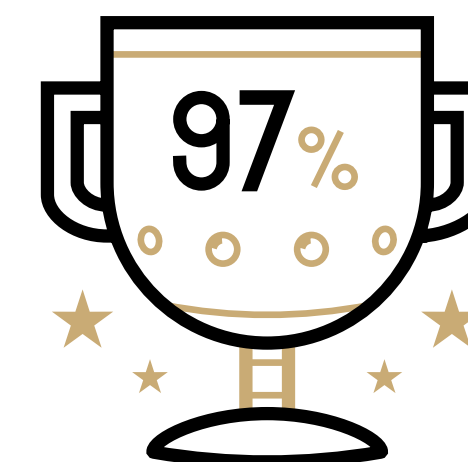

97% CUSTOMER SATISFACTION RATE

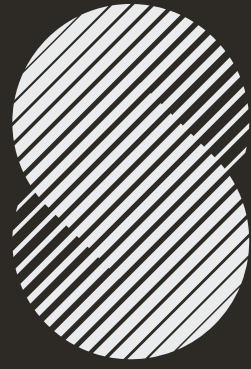

S
K
I
N
J
A
Y

A UNIQUE & INNOVATIVE CONCEPT

Thanks to our high-quality device fitted in minutes and without any work into any on-wall shower, you will be able to offer your customers :

THE POSITIVE EFFECTS
OF AROMATHERAPY DIRECTLY
IN THE SHOWER WATER.

[CLICK HERE TO WATCH A VIDEO ABOUT THE CONCEPT](#)



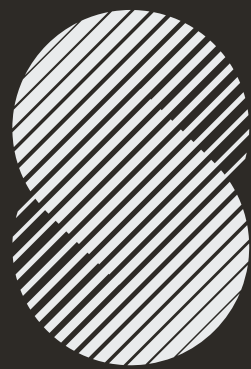

SKINJAY

UNIVERSAL AND QUICK
INSTALLATION OF THE
SKINJAY MODULE WITH
NO WORKS REQUIRED

01

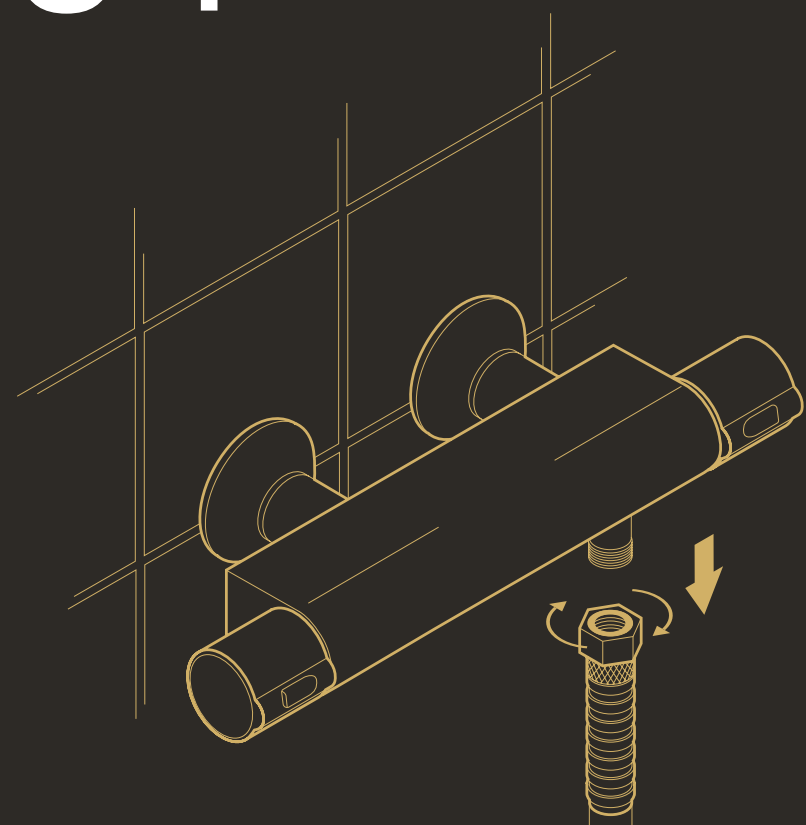

02

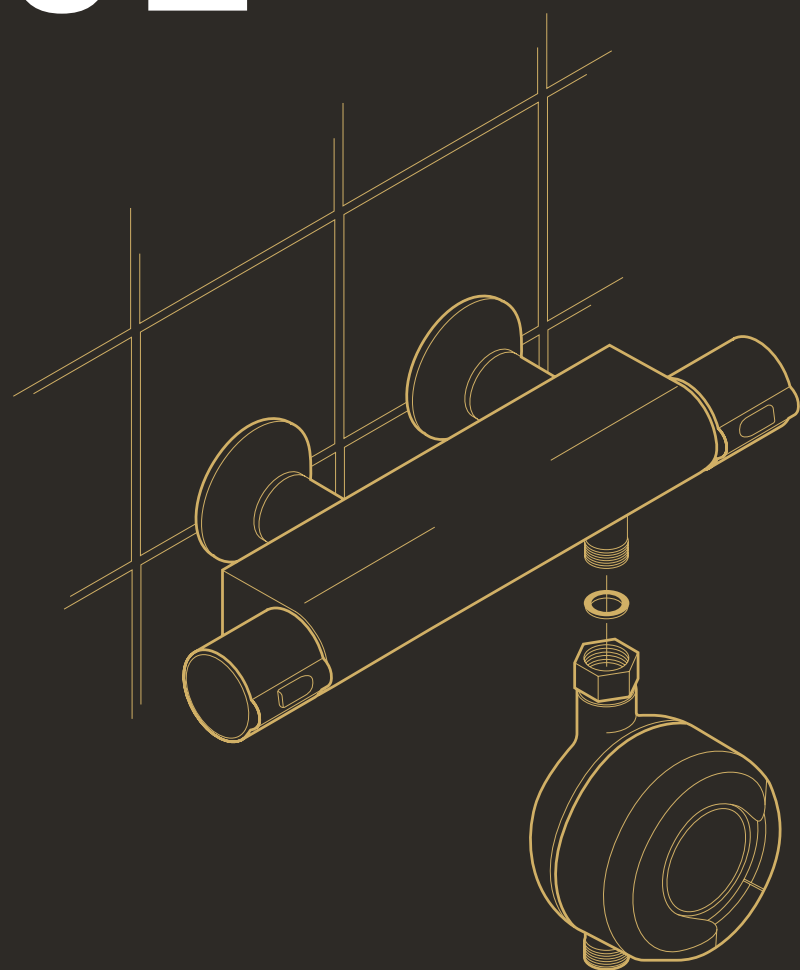

03

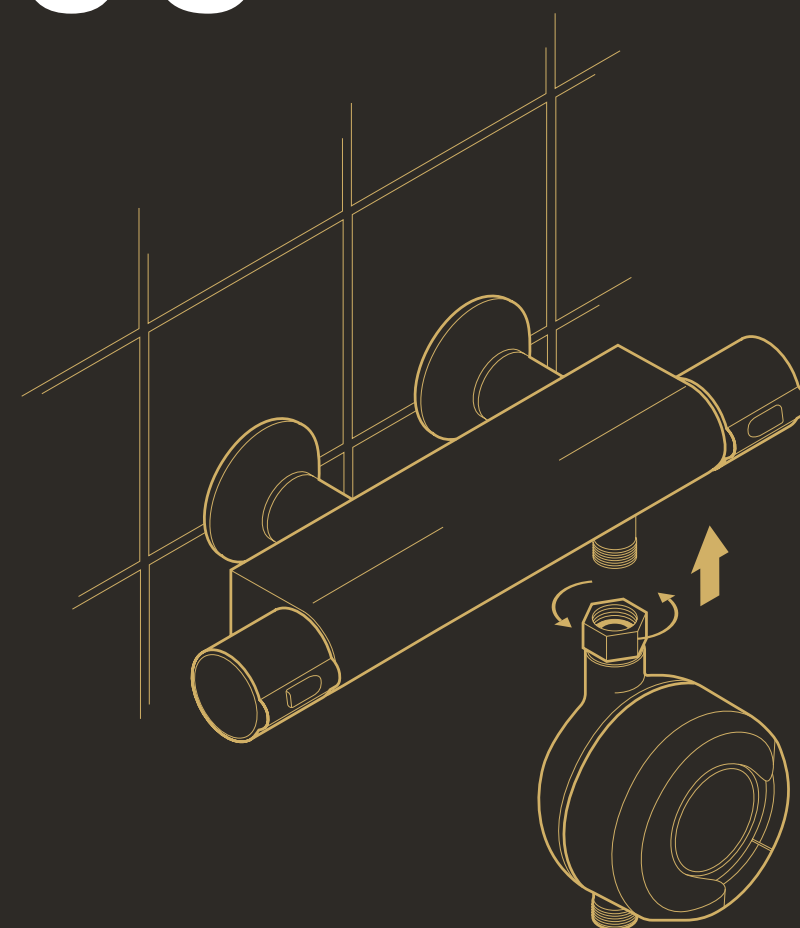

04

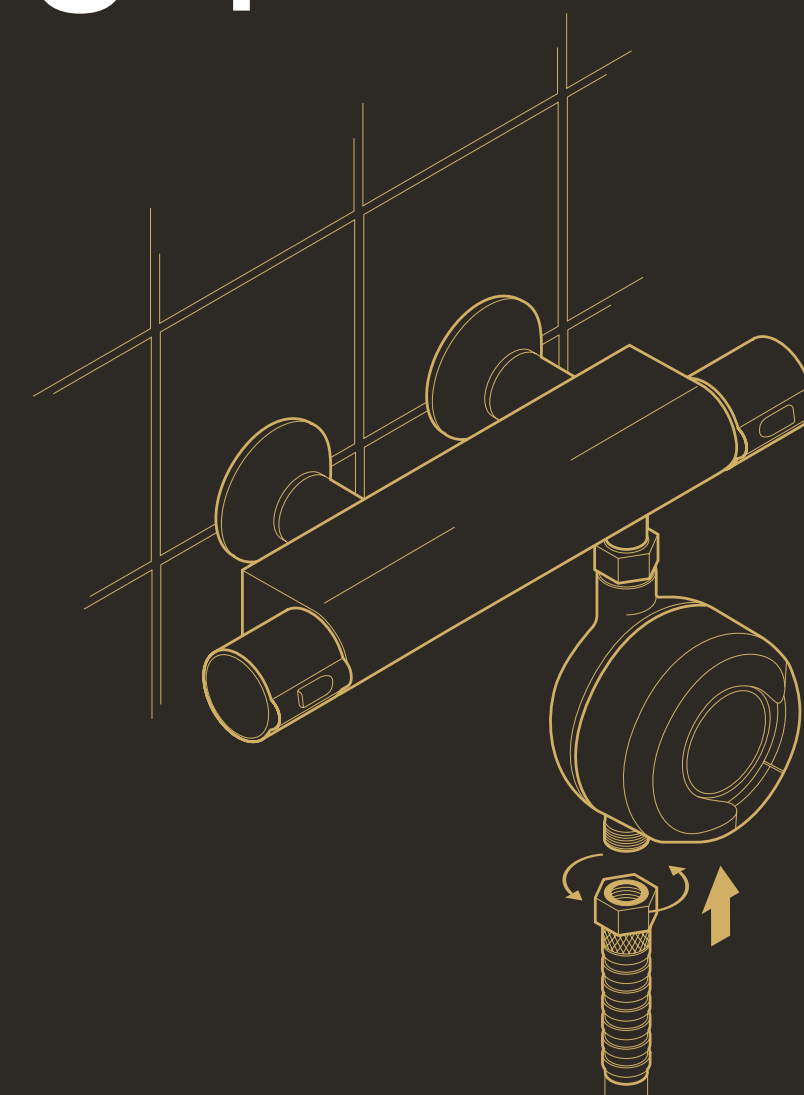

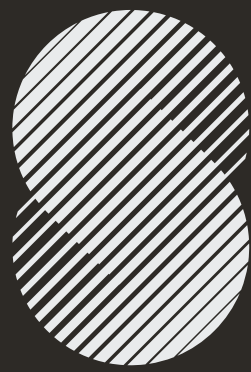

SKINJAY

YOUR CUSTOMERS WILL APPRECIATE THE EASY AND INTUITIVE USE OF SKINJAY CAPSULES

01

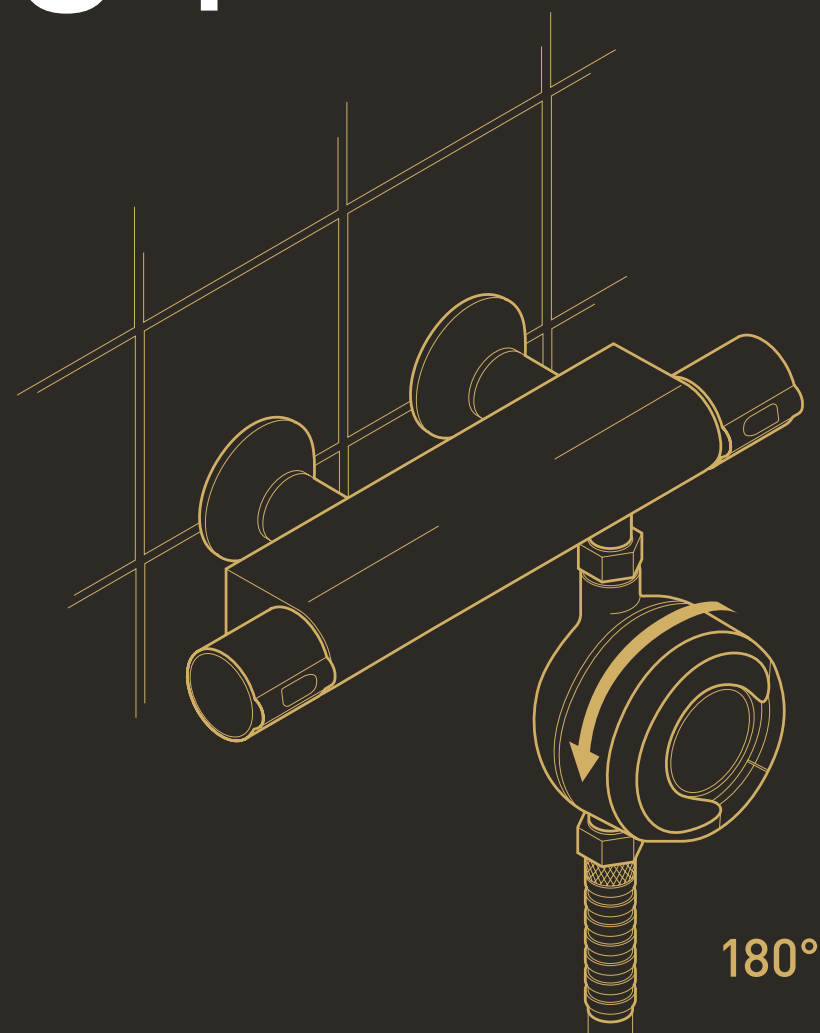

02

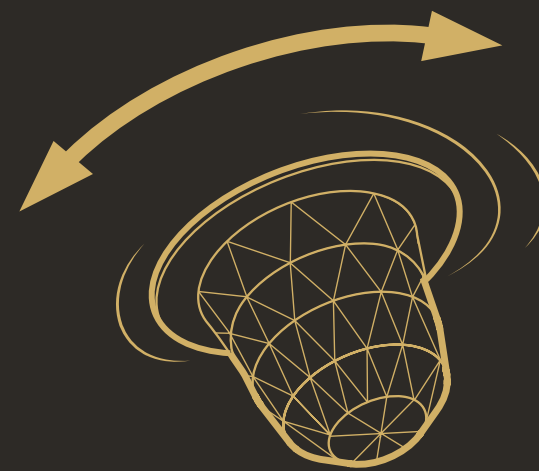

03

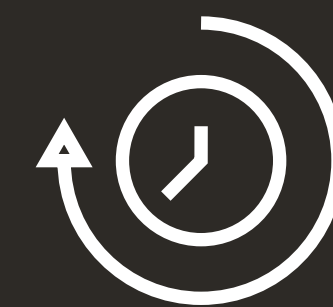
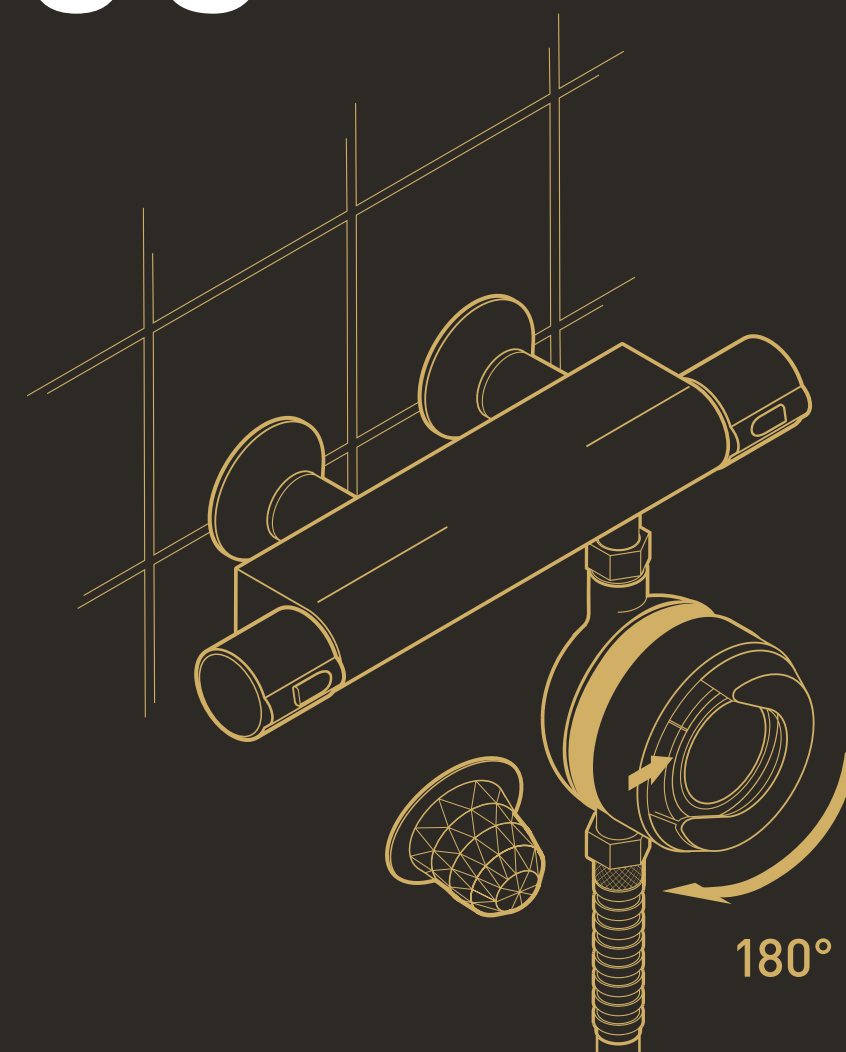

5 TO 8 MINUTES OF DIFFUSION

of essential oils into the shower water



S
K
I
N
J
A
Y

ONE PRO MODULES

PATENTED DEVICES THAT OFFER
A UNIQUE AND INNOVATIVE
METHOD OF DIFFUSING ESSENTIAL
OILS INTO SHOWER WATER.

- _ 100% Made in France
- _ High-quality materials:
lead-free brass and polyamides
- _ ACS Certification
(Certificate of Sanitary Conformity,
Attestation de Conformité Sanitaire)
- _ Easy maintenance,
as with any other tapware



Does not alter
the way a shower
typically works

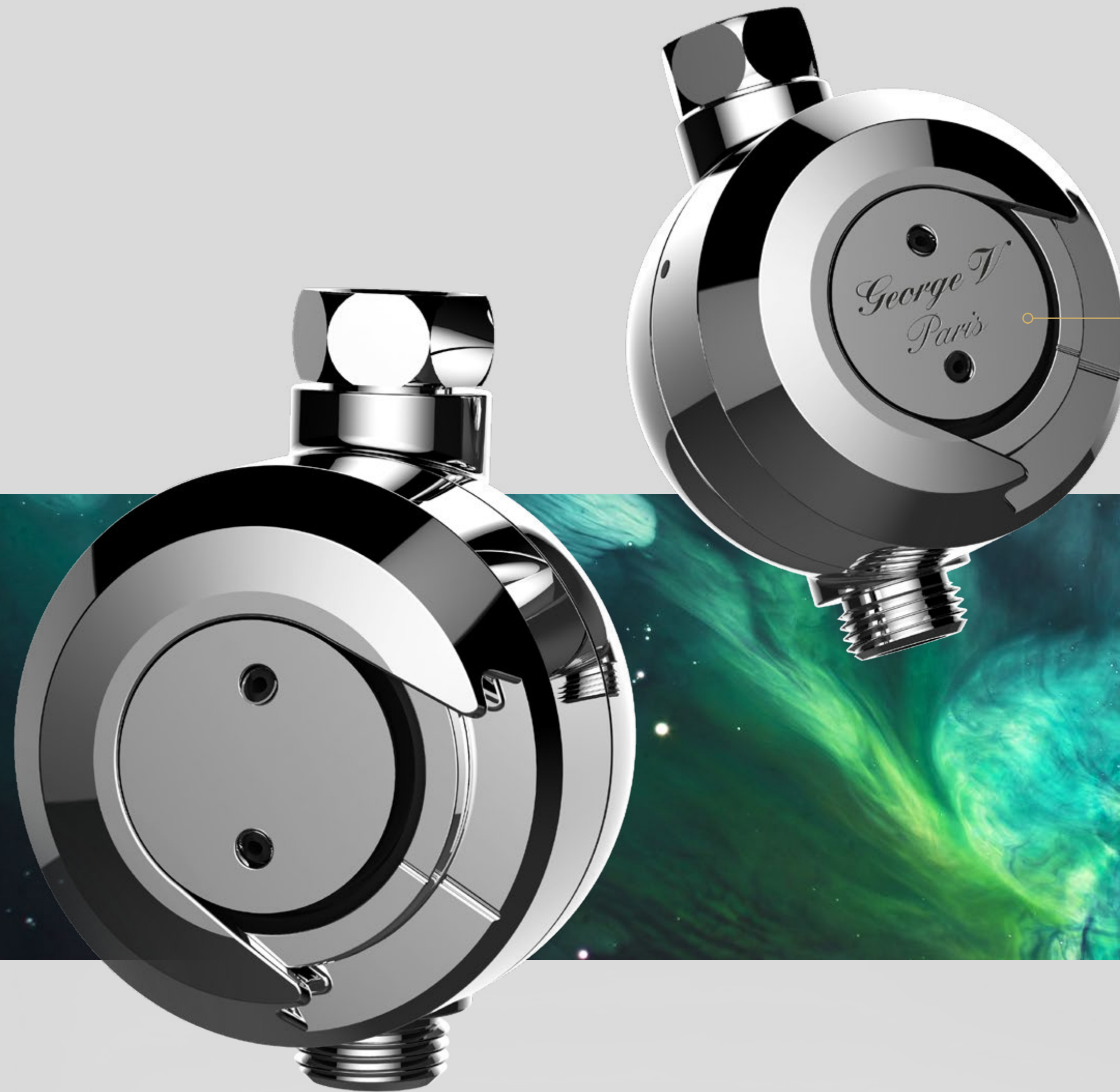

PERSONALISED
ENGRAVING
ON REQUEST



S
K
I
N
J
A
Y

SKINJAY
EXPERTISE

“ I WAS IMMEDIATELY TAKEN WITH THE IDEA OF COMBINING MIXES OF ESSENTIAL OILS WITH THE VERY HEART OF SHOWER WATER TO MAKE IT A MOMENT OF WELL-BEING THAT HELPS YOU DISENGAGE AND TAKE ADVANTAGE OF THE BENEFITS OF A RESPECTFUL AND BENEFICIAL AROMATHERAPY. ”

JEAN CHARLES SOMMERARD

Sevessence Paris

Master perfumer,
aromatherapy expert
specialised in essential oils.
Creator of olfactory, cosmetic,
and gustatory sensory signatures.





S
K
I
N
J
A
Y

AROMATHERAPY CAPSULES FOR THE SHOWER

MADE UP OF MIXES
OF ESSENTIAL OILS,
THEY MEET YOUR
CUSTOMERS' TARGETED NEEDS.

100%

MANUFACTURE MADE IN FRANCE
RECYCLABLE MATERIALS
NATURAL FRAGRANCES

- _ Non-washing, non-foaming, and non-oily.
- _ Subject to the EU Cosmetics Regulation.
- _ Undergo dermatological and toxicological assessments.



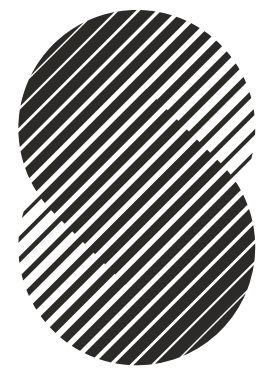

S
K
I
N
J
A
Y

AROMATHERAPY CAPSULES FOR THE SHOWER

AN APPROACH TAILORED
TO THE WISHES AND NEEDS
OF YOUR CUSTOMERS.



«I have to admit that the aromatherapy capsules that you can add to the shower really made my night after a long day working.»

 [tripadvisor](#) - Renaissance Paris Vendome Hotel



REST HONEY ODYSSEY

*Neroli
Sandalwood
Roman Camomile*

**AN INVITATION
TO PAMPER
YOURSELF**



COCOONING COCOON ODYSSEY

*Cinnamon
Sweet Orange
Nutmeg*

**COMFORTS,
WARMS UP
AND SOOTHES**



RELAX SMOOTH ODYSSEY

*Lavender
Tea Tree
Vanilla*

**ENCOURAGES
RELAXATION
AND FULFILMENT**

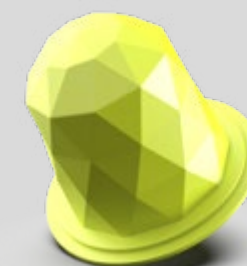

PARTY SUNSHINE ODYSSEY

*Peppermint
Sweet Lime
Davana*

**PREPARES
FOR A CRAZY
EVENING**



PLAY MAGIC ODYSSEY

*Lime
Cinnamon
Patchouli*

**DELIGHTS
BOTH KIDS
AND ADULTS**



ENERGIZE TROPICAL ODYSSEY

*Neroli
Vanilla
Lemongrass*

**RECHARGES
BODY
AND MIND**



LOVE GLAMOUR ODYSSEY

*Red berries
Geranium
Vanilla*

**AWAKENS
SENSUALITY**

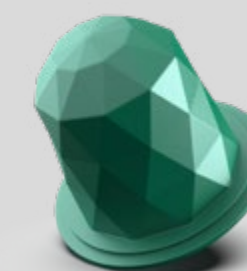

PERFORM FOREST ODYSSEY

*Lemon
scots pin
Cistus*

**MAKES YOU
FIT FOR
A HECTIC DAY**



S
K
I
N
J
A
Y

AROMATHERAPY CAPSULES FOR THE SHOWER

AN APPROACH TAILORED
TO THE WISHES AND NEEDS
OF YOUR CUSTOMERS.



«What I really liked was the «infused shower». It was the first time I tried it and I really felt refreshed from the essential oils.»

tripadvisor® - Villa Madame

SLEEP BEDTIME MISSION

*Neroli
Green Mandarin
Ylang Ylang*

PREPARE YOURSELF
FOR A NIGHT OF
RESTORATIVE SLEEP



JETLAG SMILE MISSION

*Petitgrain Bigarade
Sweet Marjoram
Lemongrass*

DISPELS
TIREDNESS
AFTER TRAVELLING



BREATHE BREATHE MISSION

*Thyme Thymol
Eucalyptus Globulus
Peppermint*

HELPS FIGHT
AGAINST COLD
AND POLLUTION



DETOX DETOX MISSION

*Fresh Carrot
Rosemary Verbenone
Juniper*

ACTIVATES
ANTI-TOXIN
MODE





S
K
I
N
J
A
Y

4 REASONS TO CHOOSE SKINJAY

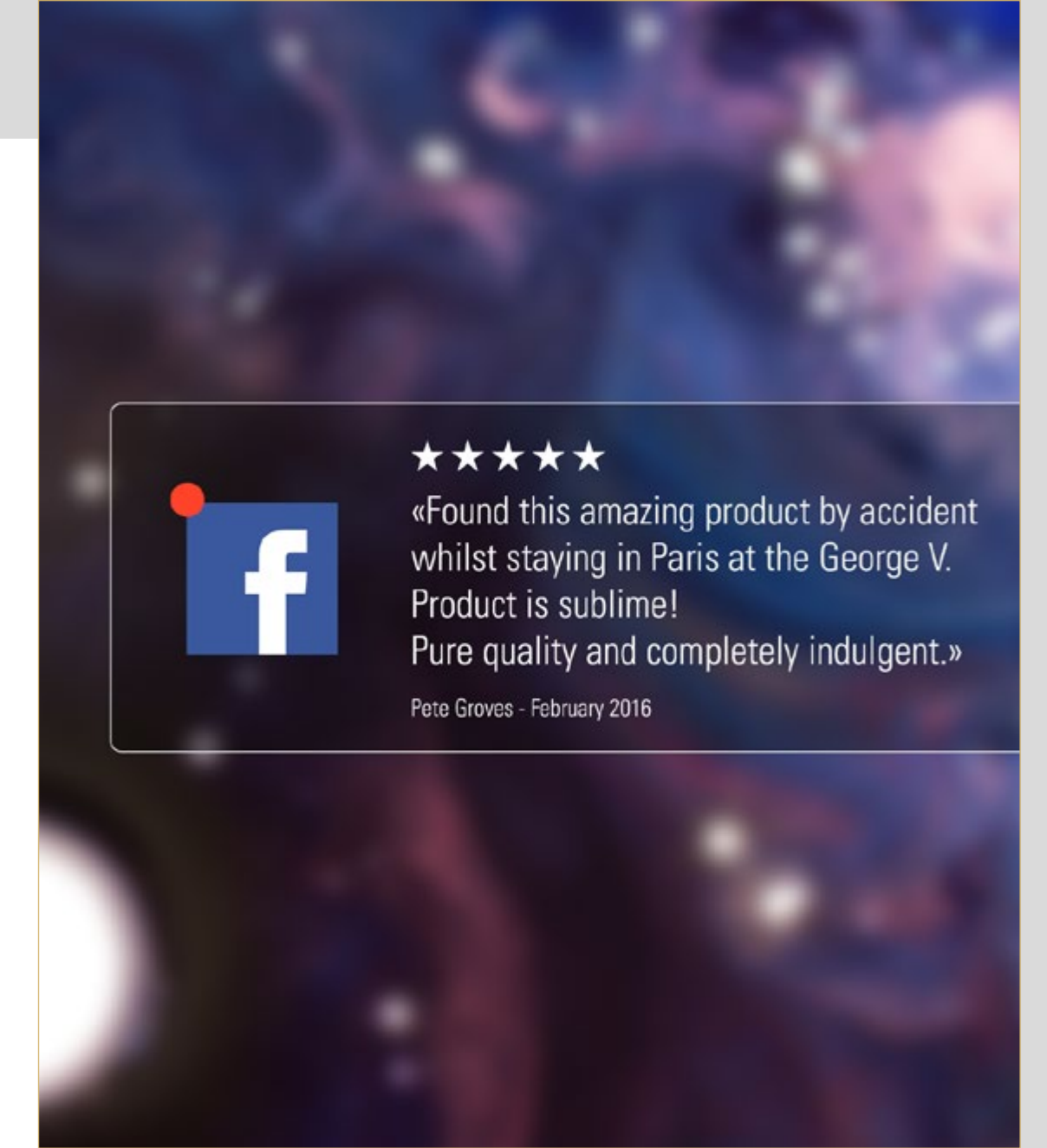

01

STAND OUT

While bathrooms in hotels worldwide have been offering the same facilities for 30 years, Skinjay lets you stand out from your competitors.

02

SURPRISE

To date, there are no other solutions next to Skinay in the hospitality industry that allow you to offer a truly new customer experience in the bathroom, without considerable investment, without the need for works, and without altering the existing amenities.

03

ATTRACT AND WIN LOYALTY

Skinjay is an answer to your customers' search for innovation and naturalness and encourages them to return. Skinjay allows you to personalise your services focused on well-being by meeting the various needs of your customers. Everyone is bound to find the capsule best suited to them depending on their mood, lifestyle, or wishes...

04

BUILD YOUR REPUTATION

Make showering an unforgettable customer experience in your hotel and a way to build your reputation. The Skinjay experience is so distinctive and surprising that your customers will be compelled to talk about it and share their thoughts on social media and travel sites.



S
K
I
N
J
A
Y

LET'S BUILD YOUR BESPOKE SKINJAY SERVICE TOGETHER

01

During the first telephone conversation, we will outline your project together.



02

We will come give a demonstration at your hotel.

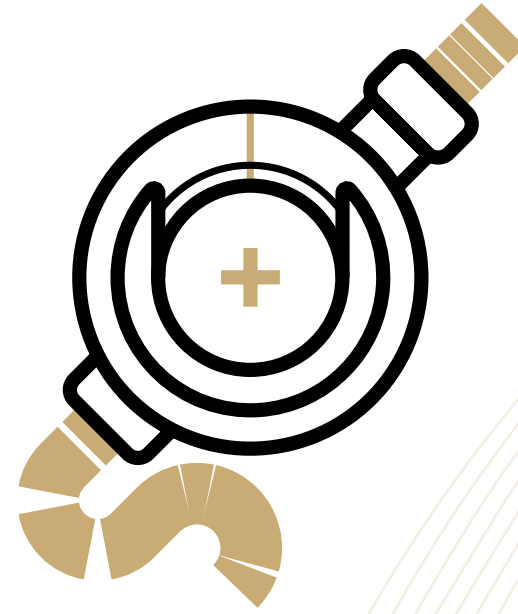

03

Your technical team will install the Skinjay Modules in your showers in a few easy steps.



04

We will provide you with the information materials that explain the capsules and how they are used to your customers.

05

We will train your in-house Skinjay sales and promotion teams.

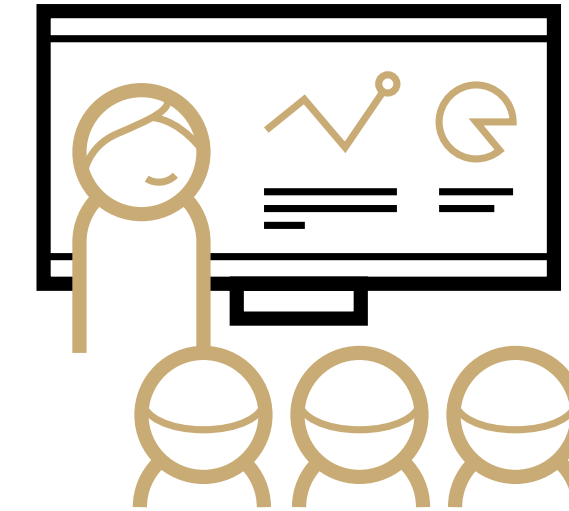

06

We will provide you with content that you can share on your various social media sites and website to promote the introduction of Skinjay.

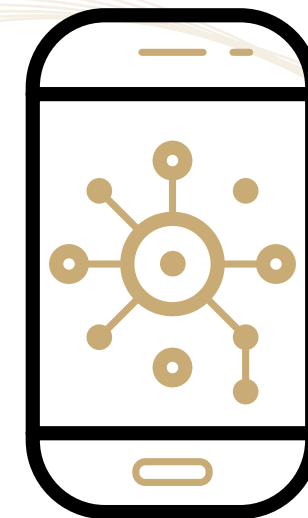

07

Your customers will be happy, return to your hotel, and share their experiences.

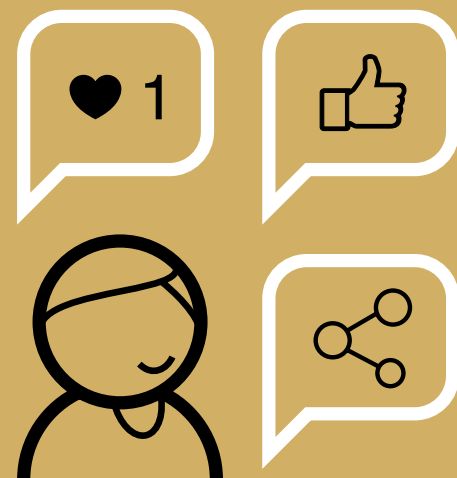



S
K
I
N
J
A
Y

TOGETHER,
LET'S BUILD
A RELATIONSHIP
OF TRUST



**A SALES
TEAM READY
TO ADVISE YOU**

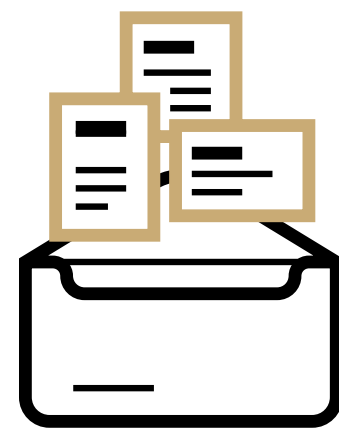

**BE THE FIRST
TO RECEIVE NEWS
AND NEW
PRODUCTS**

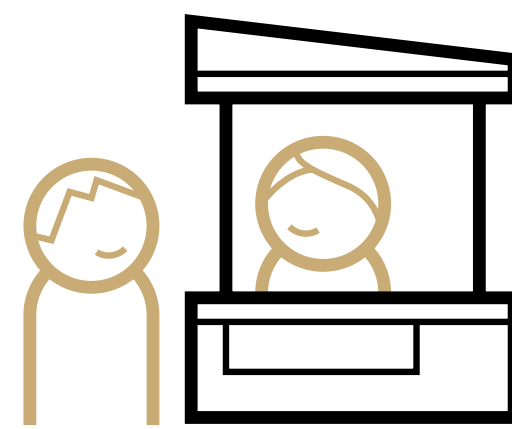

**PERSONALISED
SUPPORT DURING
SPECIFIC EVENTS**



**2-YEAR
WARRANTY**



**REPLACEMENT
IN 48H**

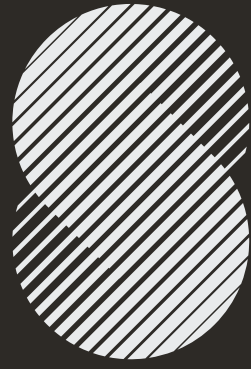

S
K
I
N
J
A
Y

THEY
TRUST US



“... PLUS THE ABILITY TO HAVE
A SHOWER SCENTED WITH ESSENTIAL OILS
(DIDN'T EVEN KNOW IT WAS POSSIBLE
BEFORE!) REALLY MADE MY STAY.
A TOUCH OF LUXURY AND PERSONNALITY
THAT MADE ME FALL IN LOVE
WITH THIS HOTEL.”

TripAdvisor - March 2015



S
K
I
N
J
A
Y



Dorchester *Collection*



“ALWAYS LISTENING TO OUR CUSTOMERS AND CONCERNED ABOUT THEIR WELL-BEING, HÔTEL PLAZA ATHÉNÉE -CONSTANTLY STRIVING FOR INNOVATION- HAS CHOSEN TO OFFER THEM A UNIQUE SERVICE FOCUSED ON SENSORIALITY AND WELL-BEING.”

LE JOURNAL DES PALACES

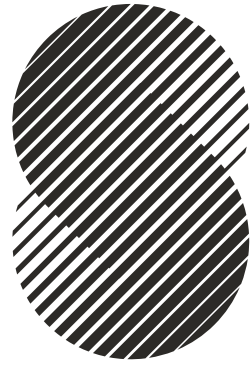

SKINJAY

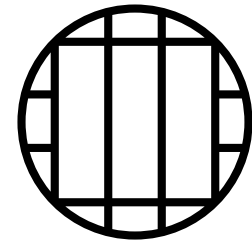

MOLITOR

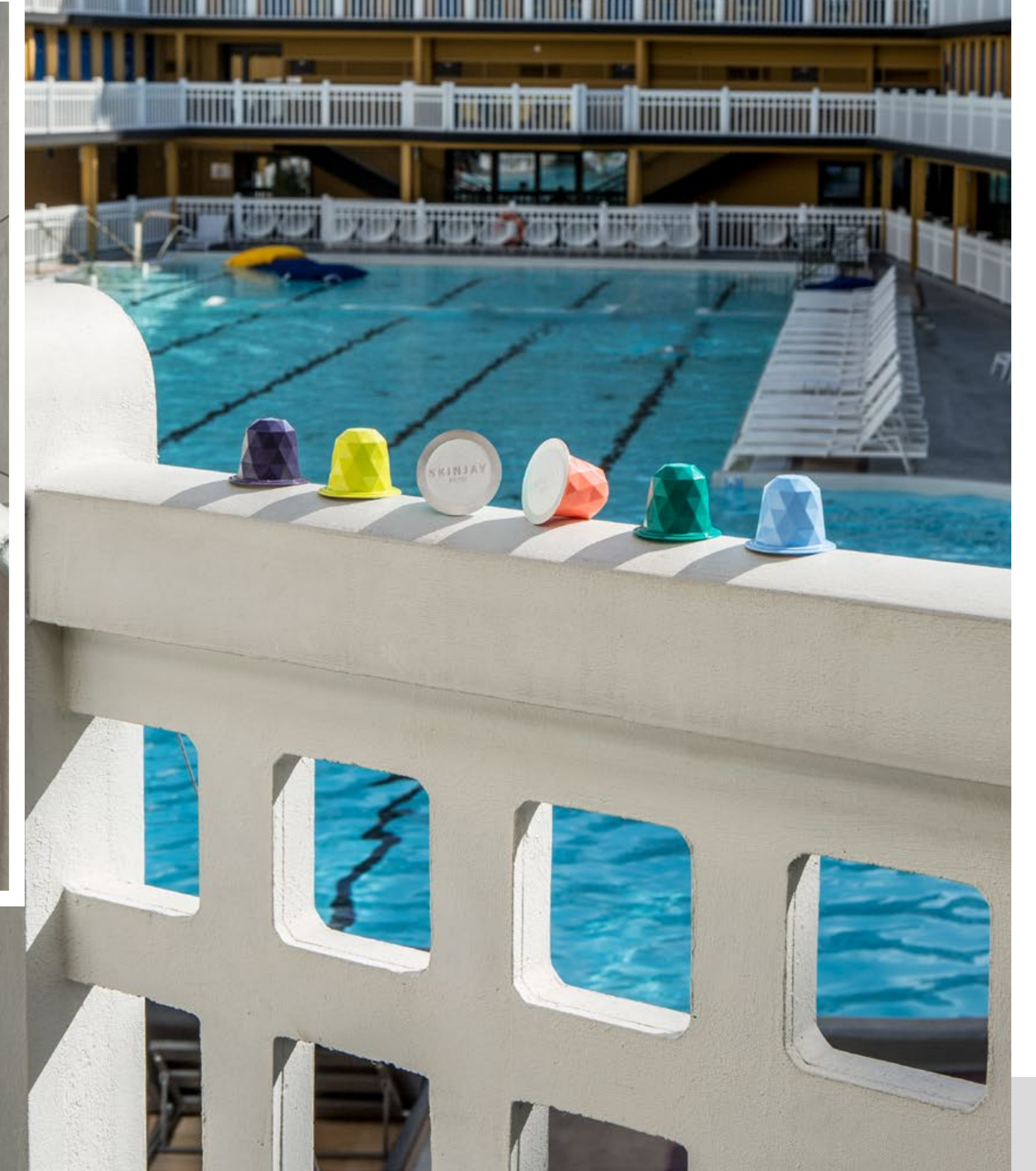



S
K
I
N
J
A
Y



the Serras
BARCELONA Luxury Boutique Hotel



“BRINGING SKINJAY INTO THE SERRAS HOTEL AS ALLOWED US TO OFFER A UNIQUE EXPERIENCE TO OUR GUESTS AND ENHANCE THE EXCLUSIVE EMOTIONAL EXPERIENCE OF THEIR STAY.”

ANTONIO BIGNONE

General manager The Serras hotel, Barcelona



S
K
I
N
J
A
Y



VILLA MAGNA
MADRID



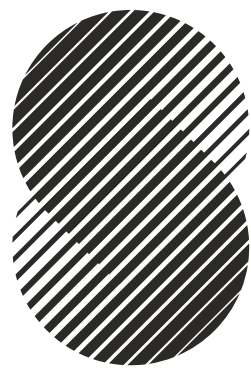

S
K
I
N
J
A
Y



GRAND HOTEL PALACE
VIA VENETO
ROMA



“ THE GRAND HOTEL PALACE IN ROME IS THE FIRST HOTEL IN ITALY TO OFFER ITS CUSTOMERS A COMPLETELY NEW SENSORY EXPERIENCE IN THE SHOWER THANKS TO SKINJAY CAPSULES. ”

LE JOURNAL DES PALACES



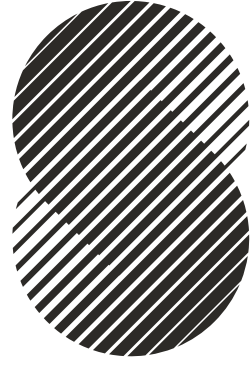

S
K
I
N
J
A
Y

AND MANY
OTHERS...



Contact our distributor in Russia:
MIKO Group of companies

officemoscow@miko-hotelservices.com
+7(495)651-09-45